

LVL Boards

Strength, Reliability and Long life



LVL BEAM & HEADER



Introduction

Designed to Outperform Traditional Lumber

Laminated Veneer Lumber (LVL) is a vast improvement over traditional lumber. Problems that naturally occur as sawn lumber dries — twisting, splitting, checking, crowning and warping — are greatly reduced.

THE STRENGTH IS IN THE ENGINEERING

LVL is made from ultrasonically and visually graded veneers that are arranged in a specific pattern to maximize the strength and stiffness of the veneers and to disperse the naturally occurring characteristics of wood, such as knots, that can weaken a sawn lumber beam. The veneers are then bonded with waterproof adhesives under pressure and heat. LVL beams are exceptionally strong, solid and straight, making them excellent for most primary load-carrying beam applications.

LVL 2.0E: AVAILABLE SIZES

LVL 2.0E is available in a range of depths and lengths, and is available in standard thicknesses of 1-3/4" and 3-1/2". The 2.0E LVL is also available in factory-laminated thicknesses (known as "billet beam") of 5-1/4" and 7" to eliminate the need for field nailing and/or bolting of multiple plies.

IMPORTANT NOTES

1. LVL shall be designed for dry-use conditions only. Dry-use applies to products installed in dry, covered and well ventilated interior conditions in which the equivalent moisture content in lumber will not exceed 16%.
2. This guide is valid only for LVL members supporting loads applied parallel under to the face of the veneers ("edge" orientation).
3. Ensure that the design loads, duration of load increases and deflection limits that you use to select products from this guide are appropriate for your application and comply code requirements. If you do not know the correct design criteria and all the loads imposed on the component from all parts of the structure, seek qualified help from the architect, engineer or designer of the structure. Additional reference data on wood construction is available in the form of building codes, code evaluation reports and other design references.
4. The Quick Reference and Allowable Load tables in this guide are only for uniform loads on simple (single) or equal, continuous (multiple) span members as noted in each table. For other conditions such as concentrated loads, unequal spans, etc., contact your LP SolidStart Engineered Wood Products distributor.
5. Spans are measured from center-to-center of supports. A structurally adequate bearing surface under the full width (thickness) of the beam must be provided at each support.
6. Minimum bearing length is 1-1/2' (at least one jack stud or cripple is required) unless otherwise noted for a specific table. Refer to the Reaction Capacity charts and the notes for each table. Verify local code requirements for minimum bearing.
7. Total load deflections are based on instantaneous loading. Long term deflection (creep) sustained load has not been considered.
8. LVL is not cambered.
9. LVL sized with the tables and design values in this guide requires continuous with local lateral restraint of the compression edge. Continuous restraint is defined as a maximum unbraced length of 24'. This restraint is normally provided by sheathing and/or other framing members, which shall be adequately anchored to the LVL and the supporting structure. Framing conditions that do not provide continuous lateral restraint require special design. Contact your Engineered Wood Products distributor. Caution: Failure to provide adequate lateral restraint could result in an unstable member and reduce its load capacity.
10. Lateral restraint shall also be provided at all supports to prevent rotation or twisting.
11. Refer to the Connection Details page for information on designing nailed and bolted connections, minimum nail spacing and end distances and for properly connecting multiple plies of LVL to form a built-up member.

LVL 2.0E Product Specifications & Design Values

ALLOWABLE STRESS DESIGN VALUES (PSI)					
Grade	Bending Stress ³ F _b	Modulus of Elasticity ⁴ E (x 10 ³)	Shear Stress F _v	Compression Stress	
				F _c (Parallel To Grain)	F _{c⊥} (Perpendicular To Grain)
2900F _b -2.0E	2900	2.0	285	3200	750

NOTES:

- LVL shall be designed for dry-use conditions only. Dry-use applies to products installed in dry, covered and well ventilated interior conditions in which the equivalent moisture content in lumber will not exceed 16%.
- The allowable strengths and stiffness are for normal load duration (10 year). Bending, Shear and Compression parallel-to-grain shall be adjusted according to code. Modulus of Elasticity and Compression perpendicular-to-grain shall not be adjusted.
- The allowable Bending Stress is tabulated for a standard 12' depth. For depths greater than 12," multiply F_b by (12/depth)^{0.143}. For depths less than 12," multiply F_b by (12/depth)^{0.143}. For depths less than 3-1/2," multiply F_b by 1.147.
- Deflection calculations shall include both bending and shear deformations.

$$\text{Deflection for a simple span, uniform load: } \Delta = \frac{270wL^4}{Ebd^3} + \frac{28.8wL^2}{Ebd}$$

Where: Δ = deflection (in) E = modulus of elasticity (psi)
 w = uniform load (plf) b = width of beam (in)
 L = design span (ft) d = depth of beam (in)

Equations for other conditions can be found in engineering references.

SECTION PROPERTIES AND ALLOWABLE CAPACITIES

Depth	Weight (lb/ft)				Allowable Moment (lb-ft)				Allowable Shear (lb)				Moment of Inertia (in ⁴)			
	1-3/4"	3-1/2"	5-1/4"	7"	1-3/4"	3-1/2"	5-1/4"	7"	1-3/4"	3-1/2"	5-1/4"	7"	1-3/4"	3-1/2"	5-1/4"	7"
7-1/4"	3.6	7.3	10.9	14.5	3918	7837	11755	15673	2411	4821	7232	9643	56	111	167	222
9-1/4"	4.6	9.3	13.9	18.5	6208	12416	18624	24832	3076	6151	9227	12303	115	231	346	462
9-1/2"	4.8	9.5	14.3	19.0	6529	13057	19586	26115	3159	6318	9476	12635	125	250	375	500
11-1/4"	5.6	11.3	16.9	22.5	8985	17970	26955	35940	3741	7481	11222	14963	208	415	623	831
11-7/8"	5.9	11.9	17.8	23.8	9951	19902	29854	39805	3948	7897	11845	15794	244	488	733	977
14"	7.0	14.0	21.0	28.0	13514	27029	40543	54057	4655	9310	13965	18620	400	800	1201	1601
16"	8.0	16.0	24.0	32.0	17318	34636	51954	69272	5320	10640	15960	21280	597	1195	1792	2389
18"	9.0	18.0	27.0	36.1	21552	43105	64657	86209	5985	11970	17955	23940	851	1701	2552	3402

NOTES:

- The Allowable Moment and Shear capacities are for normal load duration and shall be adjusted according to code.
- The tabulated Allowable Moment capacities assume continuous lateral support of the compression edge. For other conditions, multiply the Allowable Moment by the beam stability factor, C_b, as defined in the NDS.
- The 3-1/2", 5-1/4" and 7" beam widths listed above can be either a single piece or a combination of thicknesses. For example, a 7" wide beam may be a single billet beam of 7," two plies of 3-1/2," a single 1-3/4" attached to a 5-1/4" billet beam, a 3-1/2" with a 1-3/4" ply attached to each face, or four plies of 1-3/4". Refer to the Connection Assemblies details on page 14 for additional information.
- The tabulated weight is an estimate and shall only be used for design purposes.

REACTION CAPACITY (LBS)

Width	Bearing Length																					
	1-1/2"	2"	2-1/2"	3"	3-1/2"	4"	4-1/2"	5"	5-1/2"	6"	6-1/2"	7"	7-1/2"	8"	8-1/2"	9"	9-1/2"	10"	10-1/2"	11"	11-1/2"	12"
1-3/4"	1968	2625	3281	3937	4593	5250	5906	6562	7218	7875	8531	9187	9843	10500	11156	11812	12468	13125	13781	14437	15093	15750
3-1/2"	3937	5250	6562	7875	9187	10500	11812	13125	14437	15750	17062	18375	19687	21000	22312	23625	24937	26250	27562	28875	30187	31500
5-1/4"	5906	7875	9843	11812	13781	15750	17718	19687	21656	23625	25593	27562	29531	31500	33468	35437	37406	39375	41343	43312	45281	47250
7"	7875	10500	13125	15750	18375	21000	23625	26250	28875	31500	34125	36750	39375	42000	44625	47250	49875	52500	55125	57750	60375	63000

NOTES:

- The Reaction Capacity values are based on the compression strength, perpendicular-to-grain, of the LVL. This is suitable for beams bearing on steel or the end-grain of studs.
- Verify that the support for the beam is structurally adequate to carry the reaction. The compressive strength, parallel-to-grain, of studs may require more studs than the bearing length above indicates.
- For beams bearing on wood plates, the required bearing length will increase based on the bearing strength (compression perpendicular-to-grain) of the species and grade used for the plate material.
- Verify local code requirements concerning minimum bearing.

LVL 2.0E Floor Beam Quick Reference Tables

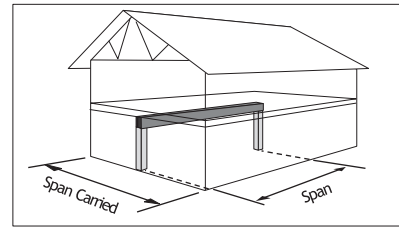

Span	Beam Width	Span Carried By Beam											
		20'	22'	24'	26'	28'	30'	32'	34'	36'	38'	40'	
6'-0"	3-1/2"	7-1/4"	7-1/4"	7-1/4"	7-1/4"	7-1/4"	7-1/4"	7-1/4"	7-1/4"	7-1/4"	7-1/4"	7-1/4"	7-1/4"
	5-1/4"	7-1/4"	7-1/4"	7-1/4"	7-1/4"	7-1/4"	7-1/4"	7-1/4"	7-1/4"	7-1/4"	7-1/4"	7-1/4"	7-1/4"
8'-0"	3-1/2"	7-1/4"	7-1/4"	9-1/4"	9-1/4"	9-1/4"	9-1/4"	9-1/4"	9-1/4"	9-1/4"	9-1/4"	9-1/4"	9-1/4"
	5-1/4"	7-1/4"	7-1/4"	7-1/4"	7-1/4"	7-1/4"	7-1/4"	7-1/4"	7-1/4"	7-1/4"	7-1/4"	7-1/4"	7-1/4"
10'-0"	3-1/2"	9-1/4"	9-1/4"	9-1/4"	9-1/2"	11-1/4"	11-1/4"	11-1/4"	11-1/4"	11-1/4"	11-1/4"	11-1/4"	11-1/4"
	5-1/4"	9-1/4"	9-1/4"	9-1/4"	9-1/4"	9-1/4"	9-1/4"	9-1/4"	9-1/4"	9-1/4"	9-1/4"	9-1/4"	9-1/2"
12'-0"	3-1/2"	11-1/4"	11-1/4"	11-1/4"	11-1/4"	11-7/8"	11-7/8"	11-7/8"	11-7/8"	11-7/8"	11-7/8"	11-7/8"	11-7/8"
	5-1/4"	9-1/4"	9-1/4"	9-1/2"	11-1/4"	11-1/4"	11-1/4"	11-1/4"	11-1/4"	11-1/4"	11-1/4"	11-1/4"	11-1/4"
14'-0"	3-1/2"	14"	14"	14"	14"	14"	14"	14"	14"	14"	14"	14"	14"
	5-1/4"	11-1/4"	11-1/4"	11-1/4"	11-1/4"	11-7/8"	11-7/8"	11-7/8"	14"	14"	14"	14"	14"
16'-0"	3-1/2"	14"	16"	16"	16"	16"	16"	16"	16"	16"	16"	16"	16"
	5-1/4"	11-7/8"	14"	14"	14"	14"	14"	14"	14"	14"	14"	16"	16"
18'-0"	3-1/2"	16"	16"	18"	18"	18"	18"	18"	18"	18"	18"	18"	18"
	5-1/4"	14"	14"	14"	16"	16"	16"	16"	16"	16"	16"	16"	16"
20'-0"	3-1/2"	18"	18"	18"	18"	18"	18"	18"	18"	18"	18"	18"	18"
	5-1/4"	16"	16"	16"	16"	18"	18"	18"	18"	18"	18"	18"	18"
22'-0"	3-1/2"	-	-	-	-	-	-	-	-	-	-	-	-
	5-1/4"	16"	18"	18"	18"	18"	18"	18"	18"	18"	18"	18"	18"
24'-0"	3-1/2"	-	-	-	-	-	-	-	-	-	-	-	-
	5-1/4"	18"	18"	-	-	-	-	-	-	-	-	-	-

Span	Beam Width	Span Carried By Beam											
		20'	22'	24'	26'	28'	30'	32'	34'	36'	38'	40'	
6'-0"	3-1/2"	7-1/4"	7-1/4"	7-1/4"	7-1/4"	7-1/4"	7-1/4"	7-1/4"	7-1/4"	7-1/4"	7-1/4"	7-1/4"	7-1/4"
	5-1/4"	7-1/4"	7-1/4"	7-1/4"	7-1/4"	7-1/4"	7-1/4"	7-1/4"	7-1/4"	7-1/4"	7-1/4"	7-1/4"	7-1/4"
8'-0"	3-1/2"	7-1/4"	7-1/4"	7-1/4"	7-1/4"	7-1/4"	9-1/4"	9-1/4"	9-1/4"	9-1/4"	9-1/4"	9-1/4"	9-1/4"
	5-1/4"	7-1/4"	7-1/4"	7-1/4"	7-1/4"	7-1/4"	7-1/4"	7-1/4"	7-1/4"	7-1/4"	7-1/4"	7-1/4"	7-1/4"
10'-0"	3-1/2"	9-1/4"	9-1/4"	9-1/4"	9-1/4"	9-1/4"	9-1/4"	9-1/2"	9-1/2"	11-1/4"	11-1/4"	11-1/4"	11-1/4"
	5-1/4"	7-1/4"	7-1/4"	9-1/4"	9-1/4"	9-1/4"	9-1/4"	9-1/4"	9-1/4"	9-1/4"	9-1/4"	9-1/4"	9-1/4"
12'-0"	3-1/2"	9-1/2"	11-1/4"	11-1/4"	11-1/4"	11-1/4"	11-1/4"	11-1/4"	11-1/4"	11-1/4"	11-7/8"	11-7/8"	11-7/8"
	5-1/4"	9-1/4"	9-1/4"	9-1/4"	9-1/4"	9-1/4"	9-1/4"	9-1/2"	11-1/4"	11-1/4"	11-1/4"	11-1/4"	11-1/4"
14'-0"	3-1/2"	11-1/4"	11-7/8"	11-7/8"	14"	14"	14"	14"	14"	14"	14"	14"	14"
	5-1/4"	11-1/4"	11-1/4"	11-1/4"	11-1/4"	11-1/4"	11-1/4"	11-1/4"	11-1/4"	11-7/8"	11-7/8"	11-7/8"	11-7/8"
16'-0"	3-1/2"	14"	14"	14"	14"	14"	16"	16"	16"	16"	16"	16"	16"
	5-1/4"	11-1/4"	11-7/8"	11-7/8"	11-7/8"	14"	14"	14"	14"	14"	14"	14"	14"
18'-0"	3-1/2"	16"	16"	16"	16"	16"	16"	16"	16"	16"	16"	16"	16"
	5-1/4"	14"	14"	14"	14"	14"	14"	14"	16"	16"	16"	16"	16"
20'-0"	3-1/2"	16"	18"	18"	18"	18"	18"	18"	18"	18"	18"	18"	18"
	5-1/4"	14"	14"	16"	16"	16"	16"	16"	16"	16"	16"	16"	18"
22'-0"	3-1/2"	18"	18"	18"	-	-	-	-	-	-	-	-	-
	5-1/4"	16"	16"	16"	16"	18"	18"	18"	18"	18"	18"	18"	18"
24'-0"	3-1/2"	-	-	-	-	-	-	-	-	-	-	-	-
	5-1/4"	18"	18"	18"	18"	18"	18"	18"	-	-	-	-	-

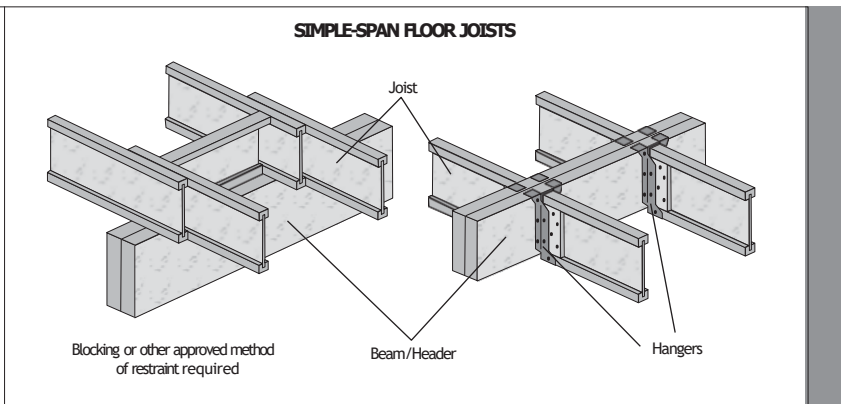
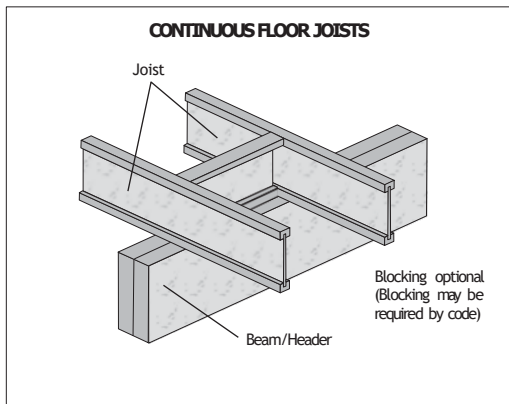

LVL 2.0E Combined Beam Quick Reference Tables

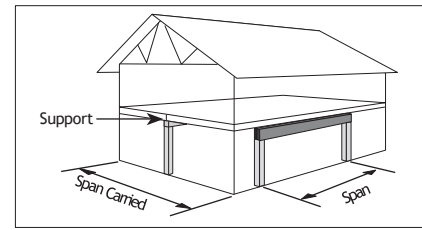

Span	Beam Width	Span Carried By Beam										
		20'	22'	24'	26'	28'	30'	32'	34'	36'	38'	40'
6'-0"	3-1/2"	7-1/4"	7-1/4"	7-1/4"	7-1/4"	7-1/4"	7-1/4"	7-1/4"	7-1/4"	7-1/4"	7-1/4"	7-1/4"
	5-1/4"	7-1/4"	7-1/4"	7-1/4"	7-1/4"	7-1/4"	7-1/4"	7-1/4"	7-1/4"	7-1/4"	7-1/4"	7-1/4"
8'-0"	3-1/2"	9-1/4"	9-1/4"	9-1/4"	9-1/4"	9-1/4"	9-1/4"	9-1/4"	9-1/4"	9-1/4"	9-1/4"	9-1/4"
	5-1/4"	7-1/4"	7-1/4"	7-1/4"	7-1/4"	7-1/4"	7-1/4"	9-1/4"	9-1/4"	9-1/4"	9-1/4"	9-1/4"
9'-6"	3-1/2"	9-1/4"	9-1/4"	9-1/4"	9-1/2"	11-1/4"	11-1/4"	11-1/4"	11-1/4"	11-1/4"	11-1/4"	11-1/4"
	5-1/4"	9-1/4"	9-1/4"	9-1/4"	9-1/4"	9-1/4"	9-1/4"	9-1/4"	9-1/4"	9-1/4"	9-1/4"	9-1/2"
10'-0"	3-1/2"	9-1/4"	9-1/2"	11-1/4"	11-1/4"	11-1/4"	11-1/4"	11-1/4"	11-1/4"	11-1/4"	11-1/4"	11-7/8"
	5-1/4"	9-1/4"	9-1/4"	9-1/4"	9-1/4"	9-1/4"	9-1/4"	9-1/4"	9-1/2"	9-1/2"	11-1/4"	11-1/4"
12'-0"	3-1/2"	11-1/4"	11-7/8"	11-7/8"	14"	14"	14"	14"	14"	14"	14"	14"
	5-1/4"	11-1/4"	11-1/4"	11-1/4"	11-1/4"	11-1/4"	11-1/4"	11-1/4"	11-1/4"	11-7/8"	11-7/8"	11-7/8"
14'-0"	3-1/2"	14"	14"	14"	14"	16"	16"	16"	16"	16"	16"	16"
	5-1/4"	11-1/4"	11-7/8"	11-7/8"	14"	14"	14"	14"	14"	14"	14"	14"
16'-0"	3-1/2"	16"	16"	16"	16"	18"	18"	18"	18"	18"	-	-
	5-1/4"	14"	14"	14"	14"	16"	16"	16"	16"	16"	16"	16"
16'-6"	3-1/2"	16"	-	-	-	-	-	-	-	-	-	-
	5-1/4"	14"	14"	14"	16"	16"	16"	16"	16"	-	-	-
18'-0"	3-1/2"	18"	18"	18"	18"	-	-	-	-	-	-	-
	5-1/4"	16"	16"	16"	16"	16"	18"	18"	18"	18"	18"	18"
18'-6"	3-1/2"	-	-	-	-	-	-	-	-	-	-	-
	5-1/4"	16"	16"	16"	16"	18"	18"	-	-	-	-	-
20'-0"	3-1/2"	-	-	-	-	-	-	-	-	-	-	-
	5-1/4"	16"	18"	18"	18"	18"	18"	-	-	-	-	-
22'-0"	3-1/2"	-	-	-	-	-	-	-	-	-	-	-
	5-1/4"	18"	-	-	-	-	-	-	-	-	-	-
24'-0"	3-1/2"	-	-	-	-	-	-	-	-	-	-	-
	5-1/4"	-	-	-	-	-	-	-	-	-	-	-

Span	Beam Width	Span Carried By Beam										
		20'	22'	24'	26'	28'	30'	32'	34'	36'	38'	40'
6'-0"	3-1/2"	7-1/4"	7-1/4"	7-1/4"	7-1/4"	7-1/4"	7-1/4"	7-1/4"	7-1/4"	7-1/4"	7-1/4"	9-1/4"
	5-1/4"	7-1/4"	7-1/4"	7-1/4"	7-1/4"	7-1/4"	7-1/4"	7-1/4"	7-1/4"	7-1/4"	7-1/4"	7-1/4"
8'-0"	3-1/2"	9-1/4"	9-1/4"	9-1/4"	9-1/4"	9-1/4"	9-1/4"	9-1/4"	9-1/4"	9-1/4"	9-1/2"	11-1/4"
	5-1/4"	7-1/4"	7-1/4"	7-1/4"	7-1/4"	7-1/4"	9-1/4"	9-1/4"	9-1/4"	9-1/4"	9-1/4"	9-1/4"
9'-6"	3-1/2"	9-1/4"	9-1/2"	11-1/4"	11-1/4"	11-1/4"	11-1/4"	11-1/4"	11-1/4"	-	-	-
	5-1/4"	9-1/4"	9-1/4"	9-1/4"	9-1/4"	9-1/4"	9-1/4"	9-1/4"	9-1/2"	9-1/2"	11-1/4"	11-1/4"
10'-0"	3-1/2"	11-1/4"	11-1/4"	11-1/4"	11-1/4"	11-1/4"	11-1/4"	11-1/4"	11-1/4"	11-7/8"	11-7/8"	11-7/8"
	5-1/4"	9-1/4"	9-1/4"	9-1/4"	9-1/4"	9-1/4"	9-1/4"	9-1/2"	11-1/4"	11-1/4"	11-1/4"	11-1/4"
12'-0"	3-1/2"	11-7/8"	11-7/8"	14"	14"	14"	14"	14"	14"	14"	14"	16"
	5-1/4"	11-1/4"	11-1/4"	11-1/4"	11-1/4"	11-1/4"	11-1/4"	11-7/8"	11-7/8"	14"	14"	14"
14'-0"	3-1/2"	14"	14"	16"	16"	16"	16"	16"	16"	18"	-	-
	5-1/4"	11-7/8"	14"	14"	14"	14"	14"	14"	14"	14"	14"	16"
16'-0"	3-1/2"	16"	16"	18"	18"	18"	18"	-	-	-	-	-
	5-1/4"	14"	14"	16"	16"	16"	16"	16"	16"	16"	18"	18"
16'-6"	3-1/2"	-	-	-	-	-	-	-	-	-	-	-
	5-1/4"	14"	16"	16"	16"	16"	-	-	-	-	-	-
18'-0"	3-1/2"	18"	18"	-	-	-	-	-	-	-	-	-
	5-1/4"	16"	16"	16"	18"	18"	18"	18"	18"	18"	18"	-
18'-6"	3-1/2"	-	-	-	-	-	-	-	-	-	-	-
	5-1/4"	16"	16"	18"	-	-	-	-	-	-	-	-
20'-0"	3-1/2"	-	-	-	-	-	-	-	-	-	-	-
	5-1/4"	18"	18"	18"	18"	-	-	-	-	-	-	-
22'-0"	3-1/2"	-	-	-	-	-	-	-	-	-	-	-
	5-1/4"	-	-	-	-	-	-	-	-	-	-	-
24'-0"	3-1/2"	-	-	-	-	-	-	-	-	-	-	-
	5-1/4"	-	-	-	-	-	-	-	-	-	-	-

LVL 2.0E Roof Beam Quick Reference Tables

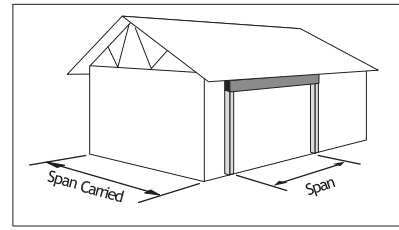

Span	Beam Width	Span Carried By Beam											
		20'	22'	24'	26'	28'	30'	32'	34'	36'	38'	40'	
6'-0"	3-1/2"	7-1/4"	7-1/4"	7-1/4"	7-1/4"	7-1/4"	7-1/4"	7-1/4"	7-1/4"	7-1/4"	7-1/4"	7-1/4"	7-1/4"
	5-1/4"	7-1/4"	7-1/4"	7-1/4"	7-1/4"	7-1/4"	7-1/4"	7-1/4"	7-1/4"	7-1/4"	7-1/4"	7-1/4"	7-1/4"
8'-0"	3-1/2"	7-1/4"	7-1/4"	7-1/4"	7-1/4"	7-1/4"	7-1/4"	7-1/4"	7-1/4"	7-1/4"	7-1/4"	7-1/4"	7-1/4"
	5-1/4"	7-1/4"	7-1/4"	7-1/4"	7-1/4"	7-1/4"	7-1/4"	7-1/4"	7-1/4"	7-1/4"	7-1/4"	7-1/4"	7-1/4"
9'-6"	3-1/2"	7-1/4"	7-1/4"	7-1/4"	7-1/4"	9-1/4"	9-1/4"	9-1/4"	9-1/4"	9-1/4"	9-1/4"	9-1/4"	9-1/4"
	5-1/4"	7-1/4"	7-1/4"	7-1/4"	7-1/4"	9-1/4"	9-1/4"	9-1/4"	9-1/4"	9-1/4"	9-1/4"	9-1/4"	9-1/4"
10'-0"	3-1/2"	7-1/4"	7-1/4"	9-1/4"	9-1/4"	9-1/4"	9-1/4"	9-1/4"	9-1/4"	9-1/4"	9-1/4"	9-1/4"	9-1/4"
	5-1/4"	7-1/4"	7-1/4"	7-1/4"	7-1/4"	7-1/4"	7-1/4"	7-1/4"	7-1/4"	9-1/4"	9-1/4"	9-1/4"	9-1/4"
12'-0"	3-1/2"	9-1/4"	9-1/4"	9-1/4"	9-1/4"	9-1/2"	11-1/4"	11-1/4"	11-1/4"	11-1/4"	11-1/4"	11-1/4"	11-1/4"
	5-1/4"	9-1/4"	9-1/4"	9-1/4"	9-1/4"	9-1/4"	9-1/4"	9-1/4"	9-1/4"	9-1/4"	9-1/4"	9-1/4"	9-1/4"
14'-0"	3-1/2"	11-1/4"	11-1/4"	11-1/4"	11-1/4"	11-1/4"	11-1/4"	11-7/8"	11-7/8"	11-7/8"	14"	14"	14"
	5-1/4"	9-1/4"	9-1/4"	9-1/4"	9-1/2"	9-1/2"	11-1/4"	11-1/4"	11-1/4"	11-1/4"	11-1/4"	11-1/4"	11-1/4"
16'-0"	3-1/2"	11-7/8"	11-7/8"	14"	14"	14"	14"	14"	14"	14"	14"	14"	14"
	5-1/4"	11-1/4"	11-1/4"	11-1/4"	11-1/4"	11-1/4"	11-1/4"	11-7/8"	11-7/8"	11-7/8"	14"	14"	14"
16'-6"	3-1/2"	11-7/8"	14"	14"	14"	14"	14"	14"	14"	14"	16"	16"	16"
	5-1/4"	11-1/4"	11-1/4"	11-1/4"	11-1/4"	11-1/4"	11-7/8"	11-7/8"	11-7/8"	14"	14"	14"	14"
18'-0"	3-1/2"	14"	14"	14"	14"	16"	16"	16"	16"	16"	16"	16"	16"
	5-1/4"	11-1/4"	11-7/8"	11-7/8"	14"	14"	14"	14"	14"	14"	14"	14"	14"
18'-6"	3-1/2"	14"	14"	14"	16"	16"	16"	16"	16"	16"	16"	16"	18"
	5-1/4"	11-7/8"	11-7/8"	14"	14"	14"	14"	14"	14"	14"	14"	14"	14"
20'-0"	3-1/2"	16"	16"	16"	16"	16"	16"	18"	18"	18"	18"	18"	18"
	5-1/4"	14"	14"	14"	14"	14"	14"	16"	16"	16"	16"	16"	16"
22'-0"	3-1/2"	16"	16"	18"	18"	18"	18"	18"	-	-	-	-	-
	5-1/4"	14"	14"	16"	16"	16"	16"	16"	16"	18"	18"	18"	18"
24'-0"	3-1/2"	18"	18"	18"	-	-	-	-	-	-	-	-	-
	5-1/4"	16"	16"	16"	16"	18"	18"	18"	18"	18"	18"	18"	-

Span	Beam Width	Span Carried By Beam											
		20'	22'	24'	26'	28'	30'	32'	34'	36'	38'	40'	
6'-0"	3-1/2"	7-1/4"	7-1/4"	7-1/4"	7-1/4"	7-1/4"	7-1/4"	7-1/4"	7-1/4"	7-1/4"	7-1/4"	7-1/4"	7-1/4"
	5-1/4"	7-1/4"	7-1/4"	7-1/4"	7-1/4"	7-1/4"	7-1/4"	7-1/4"	7-1/4"	7-1/4"	7-1/4"	7-1/4"	7-1/4"
8'-0"	3-1/2"	7-1/4"	7-1/4"	7-1/4"	7-1/4"	7-1/4"	7-1/4"	7-1/4"	7-1/4"	7-1/4"	7-1/4"	7-1/4"	9-1/4"
	5-1/4"	7-1/4"	7-1/4"	7-1/4"	7-1/4"	7-1/4"	7-1/4"	7-1/4"	7-1/4"	7-1/4"	7-1/4"	7-1/4"	7-1/4"
9'-6"	3-1/2"	7-1/4"	7-1/4"	9-1/4"	9-1/4"	9-1/4"	9-1/4"	9-1/4"	9-1/4"	9-1/4"	9-1/4"	9-1/4"	9-1/4"
	5-1/4"	7-1/4"	7-1/4"	7-1/4"	7-1/4"	7-1/4"	7-1/4"	7-1/4"	7-1/4"	7-1/4"	7-1/4"	9-1/4"	9-1/4"
10'-0"	3-1/2"	9-1/4"	9-1/4"	9-1/4"	9-1/4"	9-1/4"	9-1/4"	9-1/4"	9-1/4"	9-1/4"	9-1/4"	9-1/4"	9-1/4"
	5-1/4"	7-1/4"	7-1/4"	7-1/4"	7-1/4"	7-1/4"	7-1/4"	9-1/4"	9-1/4"	9-1/4"	9-1/4"	9-1/4"	9-1/4"
12'-0"	3-1/2"	9-1/4"	9-1/4"	9-1/2"	11-1/4"	11-1/4"	11-1/4"	11-1/4"	11-1/4"	11-1/4"	11-1/4"	11-1/4"	11-1/4"
	5-1/4"	9-1/4"	9-1/4"	9-1/4"	9-1/4"	9-1/4"	9-1/4"	9-1/4"	9-1/4"	9-1/4"	9-1/2"	9-1/2"	9-1/2"
14'-0"	3-1/2"	11-1/4"	11-1/4"	11-1/4"	11-1/4"	11-7/8"	11-7/8"	11-7/8"	14"	14"	14"	14"	14"
	5-1/4"	9-1/4"	9-1/4"	9-1/2"	11-1/4"	11-1/4"	11-1/4"	11-1/4"	11-1/4"	11-1/4"	11-1/4"	11-1/4"	11-1/4"
16'-0"	3-1/2"	11-7/8"	14"	14"	14"	14"	14"	14"	14"	14"	16"	16"	16"
	5-1/4"	11-1/4"	11-1/4"	11-1/4"	11-1/4"	11-7/8"	11-7/8"	11-7/8"	14"	14"	14"	14"	14"
16'-6"	3-1/2"	14"	14"	14"	14"	14"	14"	14"	16"	16"	16"	16"	16"
	5-1/4"	11-1/4"	11-1/4"	11-1/4"	11-7/8"	11-7/8"	14"	14"	14"	14"	14"	14"	14"
18'-0"	3-1/2"	14"	14"	16"	16"	16"	16"	16"	16"	16"	18"	18"	18"
	5-1/4"	11-7/8"	14"	14"	14"	14"	14"	14"	14"	14"	14"	16"	16"
18'-6"	3-1/2"	14"	16"	16"	16"	16"	16"	16"	16"	18"	-	-	-
	5-1/4"	14"	14"	14"	14"	14"	14"	14"	14"	16"	16"	16"	16"
20'-0"	3-1/2"	16"	16"	16"	16"	18"	18"	18"	18"	18"	18"	18"	18"
	5-1/4"	14"	14"	14"	14"	16"	16"	16"	16"	16"	16"	16"	16"
22'-0"	3-1/2"	18"	18"	18"	18"	18"	-	-	-	-	-	-	-
	5-1/4"	16"	16"	16"	16"	16"	16"	18"	18"	18"	18"	18"	18"
24'-0"	3-1/2"	18"	-	-	-	-	-	-	-	-	-	-	-
	5-1/4"	16"	16"	18"	18"	18"	18"	18"	-	-	-	-	-

LVL 2.0E Roof Beam Quick Reference Tables

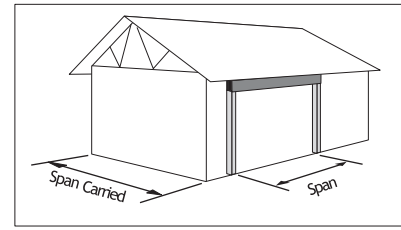

Span	Beam Width	Span Carried By Beam										
		20'	22'	24'	26'	28'	30'	32'	34'	36'	38'	40'
6'-0"	3-1/2"	7-1/4"	7-1/4"	7-1/4"	7-1/4"	7-1/4"	7-1/4"	7-1/4"	7-1/4"	7-1/4"	7-1/4"	7-1/4"
	5-1/4"	7-1/4"	7-1/4"	7-1/4"	7-1/4"	7-1/4"	7-1/4"	7-1/4"	7-1/4"	7-1/4"	7-1/4"	7-1/4"
8'-0"	3-1/2"	7-1/4"	7-1/4"	7-1/4"	7-1/4"	7-1/4"	7-1/4"	7-1/4"	7-1/4"	7-1/4"	7-1/4"	7-1/4"
	5-1/4"	7-1/4"	7-1/4"	7-1/4"	7-1/4"	7-1/4"	7-1/4"	7-1/4"	7-1/4"	7-1/4"	7-1/4"	7-1/4"
9'-6"	3-1/2"	9-1/4"	9-1/4"	9-1/4"	9-1/4"	9-1/4"	9-1/4"	9-1/4"	9-1/4"	9-1/4"	9-1/4"	9-1/4"
	5-1/4"	7-1/4"	7-1/4"	7-1/4"	7-1/4"	7-1/4"	7-1/4"	7-1/4"	9-1/4"	9-1/4"	9-1/4"	9-1/4"
10'-0"	3-1/2"	9-1/4"	9-1/4"	9-1/4"	9-1/4"	9-1/4"	9-1/4"	9-1/4"	9-1/4"	9-1/4"	9-1/4"	9-1/4"
	5-1/4"	7-1/4"	7-1/4"	7-1/4"	7-1/4"	7-1/4"	9-1/4"	9-1/4"	9-1/4"	9-1/4"	9-1/4"	9-1/4"
12'-0"	3-1/2"	9-1/4"	9-1/2"	11-1/4"	11-1/4"	11-1/4"	11-1/4"	11-1/4"	11-1/4"	11-1/4"	11-1/4"	11-7/8"
	5-1/4"	9-1/4"	9-1/4"	9-1/4"	9-1/4"	9-1/4"	9-1/4"	9-1/4"	9-1/4"	9-1/2"	11-1/4"	11-1/4"
14'-0"	3-1/2"	11-1/4"	11-1/4"	11-7/8"	11-7/8"	11-7/8"	14"	14"	14"	14"	14"	14"
	5-1/4"	9-1/2"	11-1/4"	11-1/4"	11-1/4"	11-1/4"	11-1/4"	11-1/4"	11-1/4"	11-1/4"	11-7/8"	11-7/8"
16'-0"	3-1/2"	14"	14"	14"	14"	14"	14"	14"	16"	16"	16"	16"
	5-1/4"	11-1/4"	11-1/4"	11-7/8"	11-7/8"	11-7/8"	14"	14"	14"	14"	14"	14"
16'-6"	3-1/2"	14"	14"	14"	14"	14"	16"	16"	16"	16"	-	-
	5-1/4"	11-1/4"	11-7/8"	11-7/8"	14"	14"	14"	14"	14"	14"	14"	14"
18'-0"	3-1/2"	14"	16"	16"	16"	16"	16"	16"	16"	18"	18"	18"
	5-1/4"	14"	14"	14"	14"	14"	14"	14"	16"	16"	16"	16"
18'-6"	3-1/2"	16"	16"	16"	16"	16"	18"	18"	-	-	-	-
	5-1/4"	14"	14"	14"	14"	14"	14"	16"	16"	16"	16"	16"
20'-0"	3-1/2"	16"	16"	18"	18"	18"	18"	18"	-	-	-	-
	5-1/4"	14"	14"	16"	16"	16"	16"	16"	16"	16"	18"	18"
22'-0"	3-1/2"	18"	18"	18"	-	-	-	-	-	-	-	-
	5-1/4"	16"	16"	16"	16"	18"	18"	18"	18"	18"	18"	-
24'-0"	3-1/2"	-	-	-	-	-	-	-	-	-	-	-
	5-1/4"	18"	18"	18"	18"	18"	-	-	-	-	-	-

Span	Beam Width	Span Carried By Beam										
		20'	22'	24'	26'	28'	30'	32'	34'	36'	38'	40'
6'-0"	3-1/2"	7-1/4"	7-1/4"	7-1/4"	7-1/4"	7-1/4"	7-1/4"	7-1/4"	7-1/4"	7-1/4"	7-1/4"	7-1/4"
	5-1/4"	7-1/4"	7-1/4"	7-1/4"	7-1/4"	7-1/4"	7-1/4"	7-1/4"	7-1/4"	7-1/4"	7-1/4"	7-1/4"
8'-0"	3-1/2"	7-1/4"	7-1/4"	7-1/4"	9-1/4"	9-1/4"	9-1/4"	9-1/4"	9-1/4"	9-1/4"	9-1/4"	9-1/4"
	5-1/4"	7-1/4"	7-1/4"	7-1/4"	7-1/4"	7-1/4"	7-1/4"	7-1/4"	7-1/4"	7-1/4"	7-1/4"	7-1/4"
9'-6"	3-1/2"	9-1/4"	9-1/4"	9-1/4"	9-1/4"	9-1/4"	9-1/4"	9-1/4"	9-1/4"	9-1/2"	11-1/4"	11-1/4"
	5-1/4"	7-1/4"	7-1/4"	9-1/4"	9-1/4"	9-1/4"	9-1/4"	9-1/4"	9-1/4"	9-1/4"	9-1/4"	9-1/4"
10'-0"	3-1/2"	9-1/4"	9-1/4"	9-1/4"	9-1/4"	9-1/2"	11-1/4"	11-1/4"	11-1/4"	11-1/4"	11-1/4"	11-1/4"
	5-1/4"	9-1/4"	9-1/4"	9-1/4"	9-1/4"	9-1/4"	9-1/4"	9-1/4"	9-1/4"	9-1/4"	9-1/4"	9-1/4"
12'-0"	3-1/2"	11-1/4"	11-1/4"	11-1/4"	11-1/4"	11-1/4"	11-7/8"	11-7/8"	14"	14"	14"	14"
	5-1/4"	9-1/4"	9-1/4"	9-1/2"	9-1/2"	11-1/4"	11-1/4"	11-1/4"	11-1/4"	11-1/4"	11-1/4"	11-1/4"
14'-0"	3-1/2"	11-7/8"	14"	14"	14"	14"	14"	14"	14"	16"	16"	16"
	5-1/4"	11-1/4"	11-1/4"	11-1/4"	11-1/4"	11-7/8"	11-7/8"	11-7/8"	14"	14"	14"	14"
16'-0"	3-1/2"	14"	14"	16"	16"	16"	16"	16"	16"	18"	18"	18"
	5-1/4"	11-7/8"	14"	14"	14"	14"	14"	14"	14"	14"	16"	16"
16'-6"	3-1/2"	14"	16"	16"	16"	16"	16"	-	-	-	-	-
	5-1/4"	14"	14"	14"	14"	14"	14"	14"	16"	16"	16"	16"
18'-0"	3-1/2"	16"	16"	18"	18"	18"	18"	18"	18"	-	-	-
	5-1/4"	14"	14"	14"	16"	16"	16"	16"	16"	16"	18"	18"
18'-6"	3-1/2"	16"	18"	18"	18"	-	-	-	-	-	-	-
	5-1/4"	14"	14"	16"	16"	16"	16"	16"	16"	18"	18"	18"
20'-0"	3-1/2"	18"	18"	18"	-	-	-	-	-	-	-	-
	5-1/4"	16"	16"	16"	16"	18"	18"	18"	18"	18"	18"	-
22'-0"	3-1/2"	-	-	-	-	-	-	-	-	-	-	-
	5-1/4"	18"	18"	18"	18"	18"	-	-	-	-	-	-
24'-0"	3-1/2"	-	-	-	-	-	-	-	-	-	-	-
	5-1/4"	18"	-	-	-	-	-	-	-	-	-	-

LVL 2.0E Uniform Floor Load (PLF) Tables

Span	1-3/4" x 7-1/4"			1-3/4" x 9-1/4"			1-3/4" x 9-1/2"			1-3/4" x 11-1/4"			Span
	Live Load		Total Load	Live Load		Total Load	Live Load		Total Load	Live Load		Total Load	
	L/480	L/360		L/480	L/360		L/480	L/360		L/480	L/360		
5'			767			979			1006			1191	5'
6'	494		639			815			837			991	6'
7'	323	430	547	630		698	677		717			849	7'
8'	221	295	439	438	584	610	471		626			742	8'
9'	158	211	313	316	421	542	340	454	556	542		659	9'
9'-6"	135	180	267	271	362	513	292	390	527	468		624	9'-6"
10'	116	155	230	235	313	465	253	337	500	406	542	592	10'
11'	88	118	173	179	238	353	193	257	381	311	415	538	11'
12'	68	91	133	139	186	274	150	200	296	244	325	482	12'
13'	54	72	105	110	147	216	119	159	234	194	259	383	13'
14'	43	58	83	89	119	173	96	128	188	157	209	309	14'
15'	35	47	67	73	97	141	78	105	153	128	171	252	15'
16'	-	-	-	60	80	116	65	87	125	107	142	208	16'
16'-6"	-	-	-	55	73	105	59	79	114	97	130	190	16'-6"
17'	-	-	-	50	67	96	54	72	104	89	119	173	17'
18'	-	-	-	42	57	80	46	61	87	75	101	146	18'
18'-6"	-	-	-	39	52	74	42	56	80	70	93	134	18'-6"
19'	-	-	-	36	48	68	39	52	74	64	86	124	19'
20'	-	-	-	31	41	58	33	45	63	55	74	105	20'
21'	-	-	-	-	-	-	-	-	-	48	64	91	21'
22'	-	-	-	-	-	-	-	-	-	42	56	78	22'

Span	1-3/4" x 11-7/8"			1-3/4" x 14"			1-3/4" x 16"			1-3/4" x 18"			Span
	Live Load		Total Load	Live Load		Total Load	Live Load		Total Load	Live Load		Total Load	
	L/480	L/360		L/480	L/360		L/480	L/360		L/480	L/360		
5'			1257			1482			1694			1906	5'
6'			1046			1234			1410			1586	6'
7'			896			1056			1207			1358	7'
8'			783			923			1055			1187	8'
9'	627		695			820			937			1054	9'
9'-6"	542		659			776			887			998	9'-6"
10'	471		625	735		737			843			948	10'
11'	362	483	568	569		670			765			861	11'
12'	284	379	520	449	599	613	645		701			788	12'
13'	226	302	447	360	480	565	520		646	714		727	13'
14'	183	244	361	292	390	524	424	566	599	585		674	14'
15'	150	200	295	241	321	473	350	467	559	485		629	15'
16'	125	166	244	200	267	394	292	390	523	406	542	589	16'
16'-6"	114	152	223	183	245	360	268	358	500	373	497	571	16'-6"
17'	104	139	204	168	225	330	246	329	471	343	458	554	17'
18'	88	118	171	143	190	279	209	279	411	292	390	522	18'
18'-6"	82	109	158	132	176	257	194	258	380	271	361	494	18'-6"
19'	75	101	145	122	163	238	179	239	351	251	335	468	19'
20'	65	87	124	105	140	204	155	207	302	217	289	422	20'
21'	56	75	107	91	122	176	134	179	261	189	252	369	21'
22'	49	65	92	80	106	153	118	157	227	165	220	322	22'
23'	43	57	80	70	93	133	103	138	199	145	194	282	23'
24'	38	51	70	62	82	117	91	122	175	128	171	248	24'
25'	33	45	61	55	73	103	81	108	154	114	152	220	25'
26'	30	40	54	49	65	91	72	96	137	102	136	195	26'
27'	-	-	-	43	58	80	65	86	121	91	122	174	27'
28'	-	-	-	39	52	71	58	77	108	82	109	155	28'
29'	-	-	-	35	47	64	52	70	97	74	99	139	29'
30'	-	-	-	32	42	57	47	63	87	67	89	125	30'

ACTUAL DEFLECTION BASED ON SPAN AND LIMIT												
Span (ft)	10'	12'	14'	16'	18'	20'	22'	24'	26'	28'	30'	
L/480	1/4"	5/16"	3/8"	3/8"	7/16"	1/2"	9/16"	5/8"	5/8"	11/16"	3/4"	
L/360	5/16"	3/8"	7/16"	9/16"	5/8"	11/16"	3/4"	13/16"	7/8"	15/16"	1"	
L/240	1/2"	5/8"	11/16"	13/16"	7/8"	1"	1-1/8"	1-3/16"	1-5/16"	1-3/8"	1-1/2"	

LVL 2.0E Uniform Roof Load (PLF) Tables

Span	1-3/4" x 7-1/4"				1-3/4" x 9-1/4"				1-3/4" x 9-1/2"				1-3/4" x 11-1/4"				Span
	Snow/Live Load		Total Load		Snow/Live Load		Total Load		Snow/Live Load		Total Load		Snow/Live Load		Total Load		
	L/360	L/240	Snow 115%	Non-Snow 125%	L/360	L/240	Snow 115%	Non-Snow 125%	L/360	L/240	Snow 115%	Non-Snow 125%	L/360	L/240	Snow 115%	Non-Snow 125%	
5'			883	960			1127	1225			1157	1258			1370	1490	5'
6'	659		735	799			938	1020			963	1048			1141	1241	6'
7'	430	646	630	685	840		803	874			825	897			977	1063	7'
8'	295	443	550	587	584		702	764	628		721	784			854	929	8'
9'	211	316	418	418	421	632	624	678	454	681	641	697	723		759	825	9'
9'-6"	180	271	358	358	362	543	591	642	390	585	607	660	624		718	781	9'-6"
10'	155	233	308	308	313	470	561	610	337	506	576	626	542		682	742	10'
11'	118	177	232	232	238	358	467	473	257	386	491	510	415	623	620	674	11'
12'	91	137	179	179	186	279	367	367	200	301	397	397	325	488	567	617	12'
13'	72	108	141	141	147	221	290	290	159	239	314	314	259	388	483	513	13'
14'	58	87	113	113	119	178	233	233	128	193	252	252	209	314	413	413	14'
15'	47	71	91	91	97	146	190	190	105	157	205	205	171	257	338	338	15'
16'	39	59	75	75	80	120	156	156	87	130	169	169	142	214	279	279	16'
16'-6"	35	53	68	68	73	110	142	142	79	119	154	154	130	195	255	255	16'-6"
17'	32	49	62	62	67	101	130	130	72	109	141	141	119	179	233	233	17'
18'	-	-	-	-	57	85	109	109	61	92	118	118	101	151	196	196	18'
18'-6"	-	-	-	-	52	78	100	100	56	85	109	109	93	140	181	181	18'-6"
19'	-	-	-	-	48	72	92	92	52	78	100	100	86	129	167	167	19'
20'	-	-	-	-	41	62	78	78	45	67	85	85	74	111	143	143	20'
21'	-	-	-	-	36	54	67	67	39	58	73	73	64	96	123	123	21'
22'	-	-	-	-	31	47	58	58	34	51	63	63	56	84	106	106	22'

Span	1-3/4" x 11-7/8"				1-3/4" x 14"				1-3/4" x 16"				1-3/4" x 18"				Span
	Snow/Live Load		Total Load		Snow/Live Load		Total Load		Snow/Live Load		Total Load		Snow/Live Load		Total Load		
	L/360	L/240	Snow 115%	Non-Snow 125%	L/360	L/240	Snow 115%	Non-Snow 125%	L/360	L/240	Snow 115%	Non-Snow 125%	L/360	L/240	Snow 115%	Non-Snow 125%	
5'			1447	1573			1706	1854			1949	2119			2193	2281	5'
6'			1204	1310			1420	1544			1623	1765			1826	1929	6'
7'			1031	1122			1216	1322			1390	1511			1564	1670	7'
8'			902	981			1063	1156			1215	1321			1367	1487	8'
9'	837		801	871			944	1027			1079	1174			1214	1320	9'
9'-6"	723		758	825			894	972			1022	1111			1150	1250	9'-6"
10'	628		720	783			849	923			970	1055			1092	1187	10'
11'	483		654	711	759		771	839			881	959			992	1079	11'
12'	379	568	599	652	599		706	768	860		807	878			908	988	12'
13'	302	453	535	582	480		651	709	693		744	810			838	911	13'
14'	244	367	461	483	390	585	604	657	566		691	751	780		777	845	14'
15'	200	301	395	395	321	482	545	593	467		644	701	647		725	788	15'
16'	166	250	327	327	267	401	478	520	390	585	603	656	542		679	739	16'
16'-6"	152	228	299	299	245	367	449	483	358	537	577	628	497		658	716	16'-6"
17'	139	209	274	274	225	337	423	443	329	493	543	591	458	687	638	695	17'
18'	118	177	231	231	190	286	374	374	279	419	483	526	390	585	602	655	18'
18'-6"	109	164	212	212	176	264	345	345	258	388	457	497	361	542	570	620	18'-6"
19'	101	151	196	196	163	245	319	319	239	359	433	471	335	502	540	588	19'
20'	87	130	168	168	140	211	274	274	207	310	390	406	289	434	486	529	20'
21'	75	113	145	145	122	183	237	237	179	269	351	351	252	378	440	479	21'
22'	65	98	125	125	106	160	206	206	157	236	306	306	220	331	400	432	22'
23'	57	86	109	109	93	140	180	180	138	207	268	268	194	291	365	379	23'
24'	51	76	96	96	82	124	158	158	122	183	236	236	171	257	334	334	24'
25'	45	67	84	84	73	110	139	139	108	162	209	209	152	229	296	296	25'
26'	40	60	74	74	65	98	123	123	96	145	185	185	136	204	263	263	26'
27'	36	54	66	66	58	87	110	110	86	130	165	165	122	183	235	235	27'
28'	32	48	58	58	52	78	98	98	77	116	147	147	109	164	210	210	28'
29'	-	-	-	-	47	71	87	87	70	105	132	132	99	148	189	189	29'
30'	-	-	-	-	42	64	78	78	63	95	119	119	89	134	170	170	30'

SLOPE ADJUSTMENT FACTOR

Slope	2:12	3:12	4:12	5:12	6:12	7:12	8:12	9:12	10:12	11:12	12:12
Factor	1.014	1.031	1.055	1.084	1.119	1.158	1.202	1.250	1.302	1.357	1.415